

**DIMENSIONS**

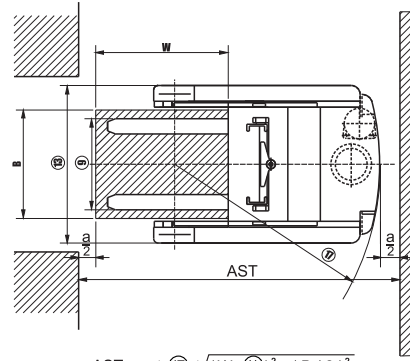

AST = a +  $\frac{W}{2}$  +  $\frac{(W-B)}{2}$   
 a : safety clearance  
 B : Pallet width  
 W : Pallet length

**LOAD CHART**

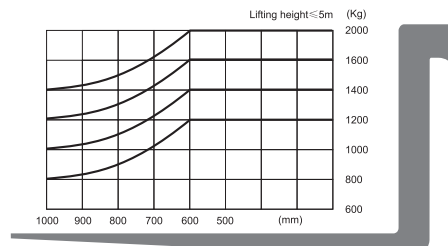

**J series Reach forklift mast specification**

Type	Model	Overall height		Free lift		Tilt range		Capacity				Tilting method	
		Lowered	Extended	With backrest		FWD	RWD	Load capacity at 600 mm					
				1.2t-1.6t	2.0t			CQD12H	CQD14H	CQD16H	CQD20H		
mm	mm	mm	mm	mm	mm	(°)	(°)	kg	kg	kg	kg		
Wide view mast	1.4QM / 2QM	2700	1925	3655	335	340	2	4	1200	1400	1600	2000	Mast tilting
		3000	2075	3955	335	340	2	4	1200	1400	1600	2000	
		3300	2225	4255	335	340	2	4	1200	1400	1600	2000	
		3500	2325	4455	335	340	2	4	1200	1400	1600	2000	
		3600	2375	4555	335	340	2	4	1200	1400	1600	2000	
		4000	2625	4955	335	340	2	4	1200	1400	1600	2000	
		4300	2790	5255	335	340	2	4	1200	1400	1600	2000	
		4500	2900	5455	335	340	2	4	1200	1400	1600	2000	
Wide view full free Triplex mast	1.4QN / 2QN	4300	2085	5255	1270	1140	2	4	1200	1400	1600	2000	Fork carriage tilting
		4500	2165	5455	1275	1220	2	4	1200	1400	1600	2000	
		4800	2265	5755	1375	1320	2	4	1200	1400	1600	2000	
		5000	2315	5955	1475	1370	2	4	1200	1400	1600	2000	
		5500	2490	6455	1625	1545	2	4	1100	1300	1500	1900	
		6000	2665	6955	1775	1720	2	5	1000	1200	1400	1800	
		6500	2815	7455	1975	1870	2	5	900	1100	1300	1600	
		7000	2975	7955	2155	2030	2	5	850	1000	1200	1400	
		7500	3145	8455	2315	2200	2	5	750	900	1100	1200	
		8000	3310	8955	2485	2365	2	5	600	700	900	1000	
8500	3510	9455	2655	2565	2	5	450	500	700	800			

■ With integrated side shift minus 200kg.

**GLOBAL SALES NETWORK**



CE CERTIFICATE



ISO14001: 2004



ISO9001: 2008

**HANGCHA GROUP CO., LTD.**  
 (Zhejiang Hangcha Imp.&Exp.Co.,Ltd.)

www.hcforlift.com

Add: 398 Shi Qiao Road, Hangzhou Zhejiang province, China(310022)  
 Factory site: No.88, Donghuan Rd., Economic Development Zone Lin'an, Zhejiang, China(311305)  
 Tel: +86-571-88926755  
 Fax: +86-571-88926789 88132890  
 E-mail: sales@hcforlift.com

HANGCHA GROUP CO., LTD. Reserves the right to make any changes without notice concerning colors, equipment, or specifications detailed in this brochure, or to discontinue individual models. The colors of trucks, delivered may differ slightly from those in brochures.

2014 VERSION 4/COPYRIGHT 2013/08

**J Series**  
 1.2/1.4/1.6/2.0t  
 Electric Reach Truck



**HANGCHA GROUP CO., LTD.**

### J series 1.2 / 1.4 / 1.6 / 2.0 ton Electric Reach Truck

The New J series Electric Reach Truck, 1.2-2.0 ton, apart from its excellent performance, is also very economical. The reach trucks are used wherever space is confined and where heavy loads are to be raised to high lift heights.

1) The drive's compartment, through generous dimensioning, provides the driver with a comfortable body position. The excellent all-around visibility and the low noise level add to the ease of working .

2) The operator compartment incorporates controls for hydraulic functions, direction control, horn, lights and handbrake, all within convenient reach of the operator. Padded armrest, rubber floor mat and resin coated control knobs ensure comfort for daylong operation. The tilt of the steering column can be freely adjusted to any degree.

3) Curtis made Multi-function instrument, together with the multi display monitor provide information and function input to the operator to allow optimum performance and operator confidence.

4) Drive and hydraulic control fitted as standard. MOSFET CHOPPER, Power transistors with high impulse frequencies control the motors in an energy saving and noiseless manner. The drive control permits jerk-free starting and a strong acceleration. Adjustable energy feedback on releasing the drive pedal through regenerative braking.

5) The chassis design and steering geometry provide an outstanding turning radius of 1675mm and reach stroke of 602mm (1.4 ton model). The steering angle of 90° in each direction further enhances maneuverability. These specifications ensure improved safety clearances in confined spaced with high loading.

6) Low noise, less pollution and energy saving, these features all satisfied with environment protection.

7) Drive and electronics cover may be opened quickly and easily for servicing and maintenance work. The service access door on the truck provides excellent access to the major service components. All motors, drive gearbox, pumps, brakes and steering are easily accessible.



### Standard Specification

- PU drive wheel & support wheel
- High capacity storage battery
- Emergency disconnect switch
- Arm rest, head protector
- High elastic seat
- Drive, lift, steering electric controlled
- LED Instrument and LCD hour meter
- 3 meters Duplex mast
- Adjustable steering column
- Front head lamp
- CURTIS MOSFET chopper controller
- Integrated sideshift

### Options

- AC motor
- Safety pedal
- 4.3-8 meters Triplex mast
- 2.7-4.5 meters Duplex mast
- With attachment
- Fast battery-charge system
- High capacity battery
- Front wheel protect cover
- Higher or wider backrest
- Side battery change



### J Series Reach forklift specification

		HANGCHA GROUP CO.,LTD.																																			
		COD12H-JC2			COD12H-JC3			COD12H-JC4			COD14H-JC2			COD14H-JC3			COD14H-JC4			COD16H-JC2			COD16H-JC3			COD16H-JC4			COD20H-JC2			COD20H-JC3			COD20H-JC4		
General	1	Manufacture																																			
	2	Model																																			
	3	Power type		Battery			Battery			Battery			Battery																								
Dimensions	4	Rated capacity		kg		1200			1400			1600			2000																						
	5	Load center		mm		600			600			600			600																						
	6	Lift height		mm		3000			3000			3000			3000																						
	7	Free lift height		mm		340			340			340			340																						
	8	Fork size		L x W x T		mm		920 × 120 × 35			920 × 120 × 35			920 × 120 × 35			1070 × 120 × 40																				
	9	Fork spread(outside)		Min. / Max.		mm		220 / 896			220 / 896			220 / 896			220 / 896																				
	10	Mast tilt range (Refer to mast table)		$\alpha^\circ / \beta^\circ$		(^)		2 / 4			2 / 4			2 / 4			2 / 4																				
	11	Axle centre to fork face		mm		390			390			330			330																						
	12	Overall dimensions		Length to face of fork		mm		1802			1802			1802			1882																				
	13			Overall width		mm		1240			1240			1240			1272																				
	14			Mast lowered height		mm		2100			2100			2100			2100																				
	15			Mast extended height		mm		3565			3565			3565			3565																				
	16	Overhead guard height		mm		2075			2075			2075			2075																						
	17	Turning radius(outside)		mm		1675			1675			1675			1755																						
	18	Min. right angle stacking aisle width (Ast)		Pallet: W x B=1200 x 1000		mm		2826			2826			2878			2958																				
	19			Pallet: W x B=800 x 1200		mm		2602			2602			2637			2717																				
	Performance	20	Speed		Travel		km/h		10.2			10.2			10.2			10.2																			
21		Lifting ( Full load )			mm/s		260			260			220			210																					
22		Extend distance		mm		602			602			542			542																						
23		Max. Gradeability ( Full load )		%		10			10			10			10																						
24	Self weight		kg		2850			2850			3000			3250																							
Wheels & tires	25	Wheels ( diameterxwidth )		Front		mm		285 x 100			285 x 100			285 x 100			343 x 108																				
	26			Drive		mm		343 x 114			343 x 114			343 x 114			343 x 114																				
	27	Wheelbase		mm		1420			1420			1420			1500																						
28	Ground clearance(Minimum)		mm		70			70			70			70																							
Drive units & control	29	Battery		Model				D-400B			D-400B			D-500			D-500																				
	30			Voltage / Capacity ( 5 HR )		V/AH		48 / 400			48 / 400			48 / 500			48 / 500																				
	31			Weight ( with box )		kg		760			760			900			900																				
	32	Electric motors		Drive		Rated output / S60min		kW		5.5(AC)		6.5(AC)		5.5(AC)		6.5(AC)		5.5(AC)		6.5(AC)		5.5(AC)		6.5(AC)													
	33			Load		Rated output / S15min		kW		12.8(AC)		8.6(DC)		12.8(AC)		8.6(DC)		12.8(AC)		8.6(DC)		12.8(AC)		8.6(DC)		12.8(AC)											
	34	Control		Manufacture				CURTIS			CURTIS			CURTIS			CURTIS																				
35	Type					AC			AC			AC			AC																						
36	Operating pressure		For attachments		MPa		14.5			14.5			14.5			14.5																					

1. Special lifting height available ( 2.7m, 3.5m, 3.6m, 4m, 4.3m, 4.5m, 4.8m, 5m, 5.5m, 6m, 6.5m, 7m, 7.5m, 8m, 8.5m).
2. Attachment available.
3. Battery charger available.
4. The specification in this table are for standard models only. For further information please contact us.
5. Specification are subject to change without notice.